

Maxi-Joint®

Control Units & Accessories

Features:

- Protects expansion joints from over- expansion and over-compression
- High tensile galvanized steel rods standard, stainless steel and other materials available
- Galvanized gusset plates standard, stainless steel and other materials available
- Rubber grommets isolate vibration and are standard on sizes 1"-12" diameter
- Internal nuts or compression sleeves available and prevent over-compression
- Spherical washers available and prevent binding while minimizing lateral forces
- Double nuts are used to lock limit points and allow for field adjustment
- Other standard drilling available, including ASA 300, DIN, PN, JIS, API, and Navy
- Universal tied / self-guiding control units available and prevent squirming on longer expansion joints
- Hinges are available and allow for angular movement in one dimension
- Gimbles are available and allow for angular movement in two dimensions

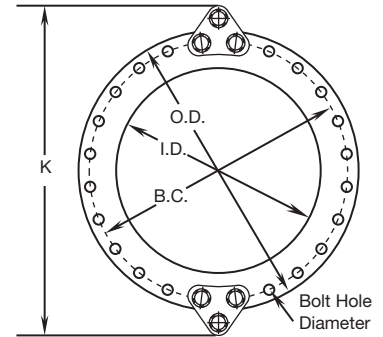
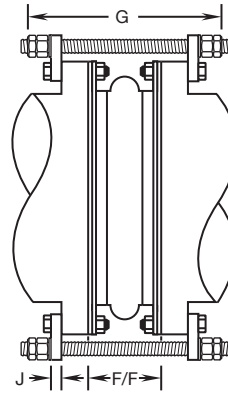

Style HCU Hinged Control Units

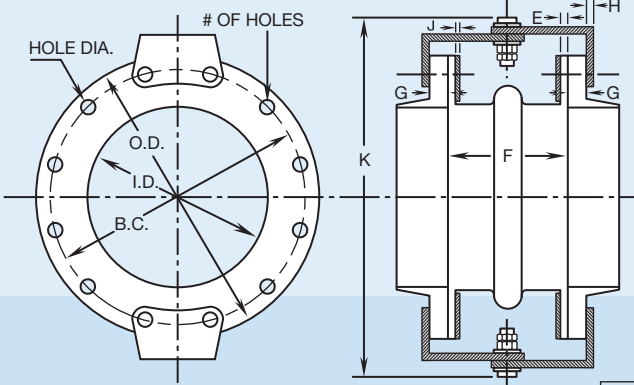

Style PG Pipe Guide

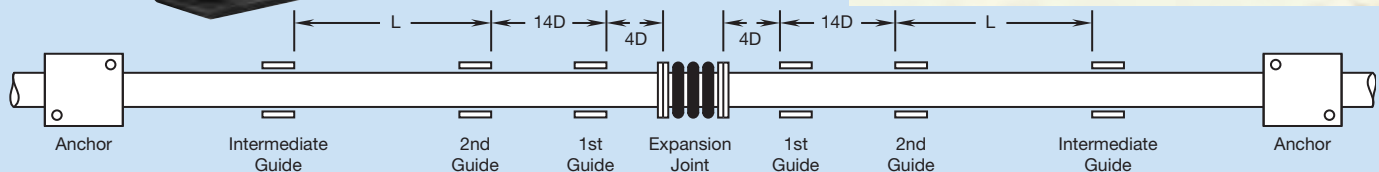
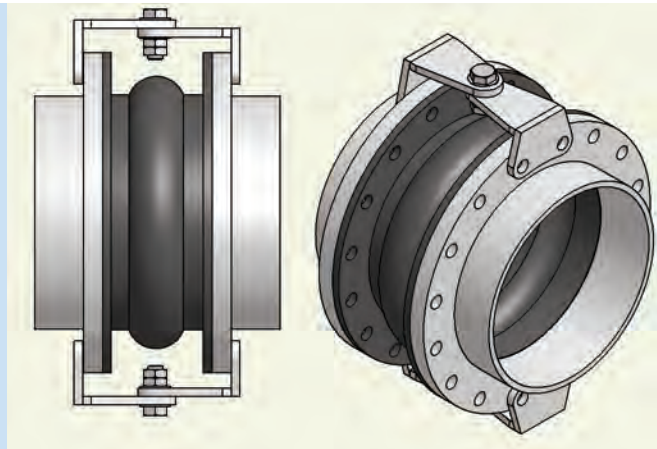
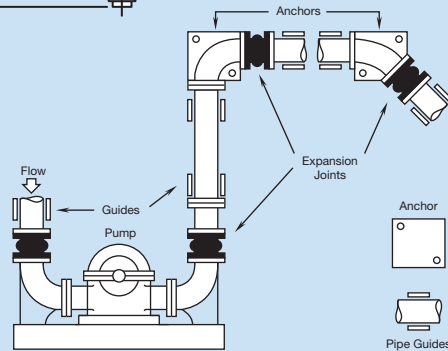
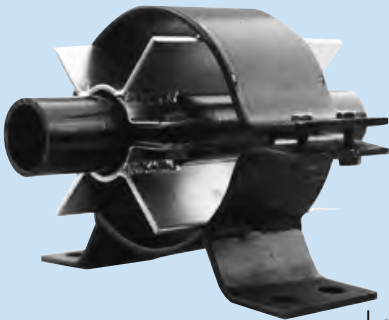

Style GR/B

Outer Grommet, Inner Bare

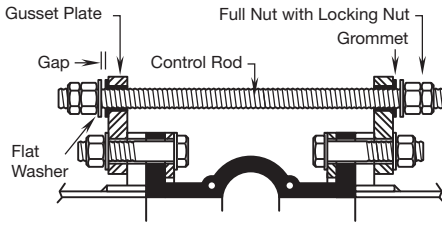

Style GR/W

Outer Grommet, Inner Washer

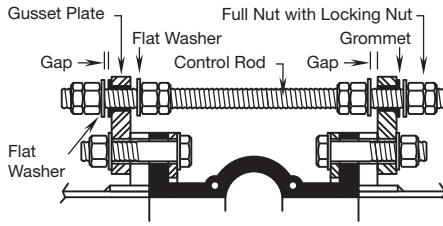

Style W/S

Outer Washer, Inner Compression Sleeve

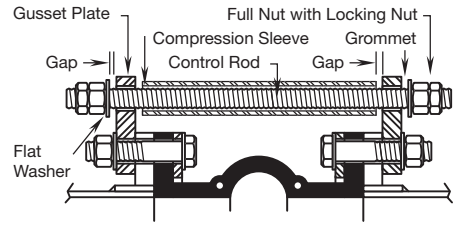

Style W/B

Outer Washer, Inner Bare

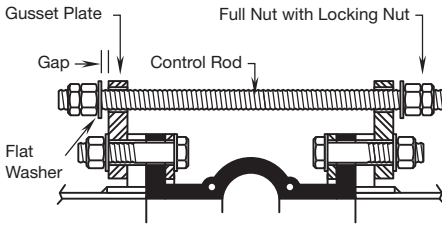

Style W/W

Outer Washer, Inner Washer

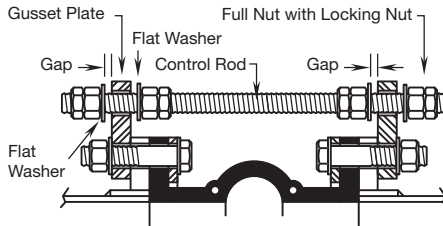

Style INT-WB

Outer Washer, Inner Bare (Integral Design)

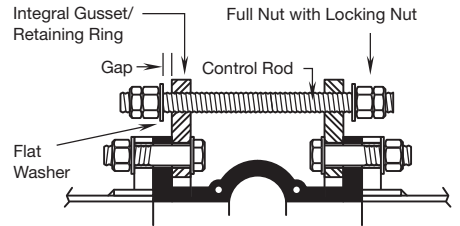

Style SW/B

Outer Spherical Washer, Inner Bare

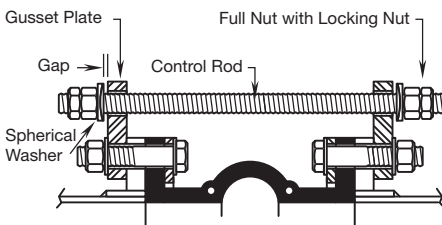

Style SW/SW

Outer Spherical Washer, Inner Spherical Washer

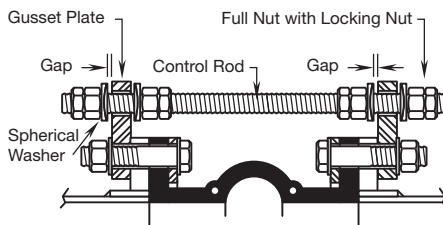

Style SW/W

Outer Spherical Washer, Inner Washer

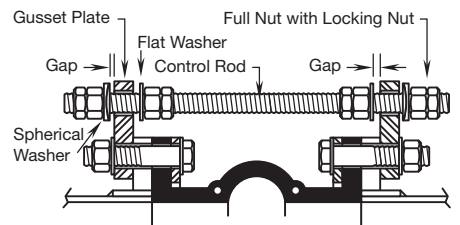

Pipe SIZE (I.D.) (inch)	Standard LENGTH (F/F) (inch)	MAX Control Unit Length (G inch)	MAX Control Unit Dia. (K inch)	MAX Gusset TH. (J inch)	2 Rod Set MAX Pressure PSI	3 Rod Set MAX Pressure PSI	4 Rod Set MAX Pressure PSI	5 Rod Set MAX Pressure PSI	6 Rod Set MAX Pressure PSI	7 Rod Set MAX Pressure PSI	8 Rod Set MAX Pressure PSI	9 Rod Set MAX Pressure PSI
1	6	16	8.6	1/2	275	-	-	-	-	-	-	-
1-1/2	6	16	9.3	1/2	275	-	-	-	-	-	-	-
2	6	16	10.3	1/2	275	-	-	-	-	-	-	-
2-1/2	6	16	11.1	1/2	275	-	-	-	-	-	-	-
3	6	16	11.6	1/2	275	-	-	-	-	-	-	-
4	6	16	13.3	1/2	275	-	-	-	-	-	-	-
5	6	16	14.4	3/4	275	-	-	-	-	-	-	-
6	6	16	15.4	3/4	275	-	-	-	-	-	-	-
8	6	16	18.5	3/4	275	-	-	-	-	-	-	-
10	8	16	21.5	3/4	200	275	-	-	-	-	-	-
12	8	16	23.5	3/4	147	220	275	-	-	-	-	-
14	8	21	24.6	1	156	234	275	-	-	-	-	-
16	8	21	27.3	1	124	186	249	-	-	-	-	-
18	8	21	28.9	1	101	151	202	-	-	-	-	-
20	8	21	31.5	1	84	126	168	-	-	-	-	-
24	10	21	36.5	1	58	87	117	145	-	-	-	-
30	10	29	43.5	1-3/8	71	106	142	-	-	-	-	-
36	10	29	51.5	1-3/8	51	76	101	-	-	-	-	-
40	12	29	56.5	1-3/8	40	59	80	99	-	-	-	-
42	12	29	57.9	1-3/8	36	54	73	91	-	-	-	-
48	12	32	65.5	2	47	70	94	-	-	-	-	-
54	12	32	72.6	2	38	56	76	94	-	-	-	-
60	12	32	79.5	2	31	46	62	78	93	-	-	-
66	12	32	86.5	2	26	38	52	65	78	90	-	-
72	12	32	92.5	2	22	33	44	55	66	77	88	-
78	12	32	99.5	2	19	28	38	47	57	66	76	85
84	12	35	106.7	2	24	36	49	61	73	86	80	-
90	12	35	113.5	2	21	32	43	54	64	75	85	-
96	12	35	120.5	2	19	28	38	47	57	66	76	85
102	12	35	127.5	2	17	25	34	42	51	59	67	76
108	12	35	134.5	2	15	22	30	38	45	53	60	68

Notes:

- Maximum Control Unit lengths and diameters, as well as gusset thickness, are meant to assist in determining adequate clearance and mating hardware selection. The values are maximum values and are based on mild steel design. Dimensions will change when using high tensile steel and with different arrangements. Contact General Rubber and request a specific submittal drawing for your job.
- Expansion joints should be installed between anchors. Anchors should be located at changes in pipe direction and guides should be spaced according to industry standards. Piping must be supported so the expansion joints do not carry any pipe weight. Contact General Rubber for more details.
- WARNING:** Control units (sold separately) must be used when piping is not properly anchored. Number of rods are dependent upon maximum field test pressures. Expansion joints may operate in pipelines carrying fluids at elevated temperatures and pressures, so precaution should be taken to ensure proper installation and regular inspection. Care is required to protect personnel in the event of leakage or splash. Adequate floor drains are always recommended.
- Outer and inner Control Unit gaps are set to a maximum of 1/2 the allowable movements, equal on each side so that the sum does not exceed the allowable movement in any one direction.

