

Maxi-Joint®

Molded Teflon® Expansion Joints

Style 3305

Features:

- Superior chemical resistance, utilizing 100% virgin Dupont Teflon®
- Low stiffness and deflection forces
- 400°F continuous service standard
- Full vacuum rating (30" Hg) in all sizes offered
- Standard face to face dimensions with threaded ANSI 125/150 lb. drilling
- Large inventory means quick shipments
- Absorbs all directional movement
- Carbon steel or stainless steel flanges
- Reduces system noise, vibration and shock
- Compensates for minor misalignment and offset
- Simple to install, lightweight and high strength
- Integral control units standard
- Provides easy access to piping and equipment
- Ideal for food, pharmaceutical, chemical and ultra pure water applications

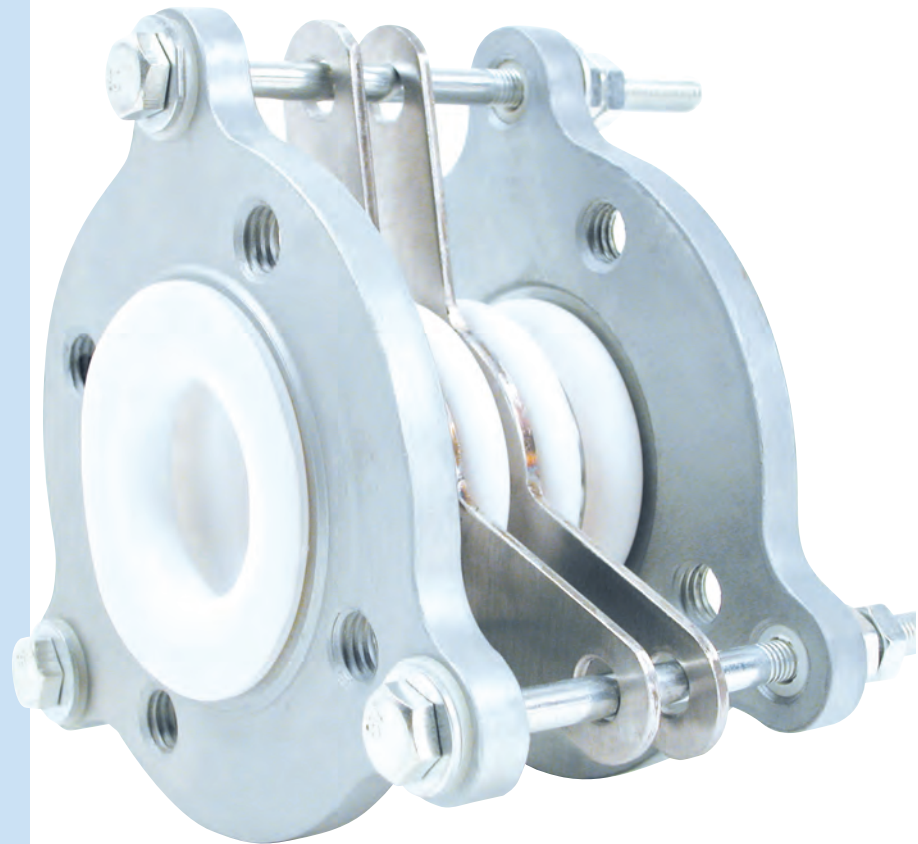

Style 3305

Five Convolution Molded Teflon® Bellows

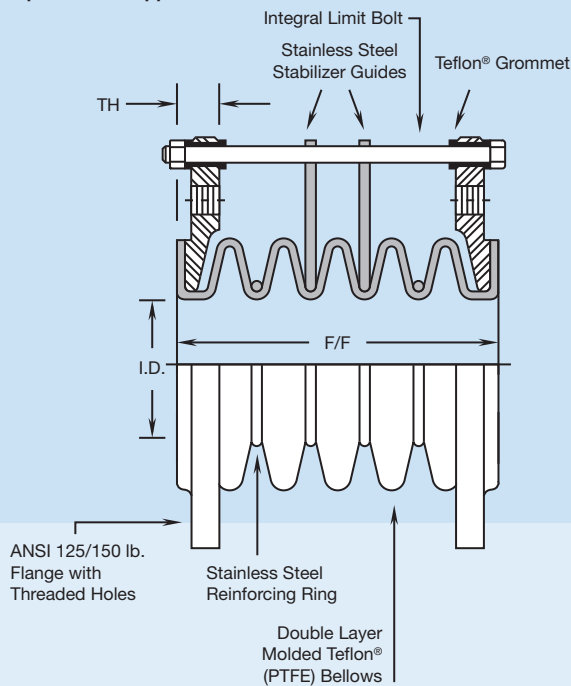

SIZE I.D. (inch)	LENGTH F/F (inch)	MAX PRESSURE (PSI)			MAX Temp (@ 30" Hg)	MAX O.D. (inch)	FLANGE O.D. (inch)	B.C. (inch)	HOLES (no.)	HOLES Thread & Dia.	TH. (inch)	MOVEMENTS				GROSS Weight (lbs)
		(@ 70°F)	(@ 200°F)	(@ 400°F)								Comp. (inch)	Ext. (inch)	Lateral (inch)	Angular (degree)	
Style 3305 Five Convolution Molded Teflon® Expansion Joints																
1	3	100	65	30	120	5-7/8	4-1/4	3-1/8	4	1/2-13	1/2	1	3/4	3/8	65	4
1-1/2	3-1/2	100	65	30	120	6-7/8	5	3-7/8	4	1/2-13	1/2	1	3/4	3/8	45	5
2	4	100	65	30	120	7-7/8	6	4-3/4	4	5/8-13	5/8	1-1/4	1	1/2	43	9
2-1/2	4	100	65	30	120	9-1/8	7	5-1/2	4	5/8-11	3/4	1-1/4	1	1/2	38	12
3	5	100	65	30	95	9-3/4	7-1/2	6	4	5/8-11	3/4	1-1/2	1-1/4	5/8	38	13
4	5-1/4	100	65	30	95	10-7/8	9	7-1/2	8	5/8-11	3/4	1-1/2	1-1/4	5/8	32	20
5	6	100	65	30	95	12-3/4	10	8-1/2	8	3/4-10	1	1-3/4	1-1/2	3/4	31	30
6	6	100	65	30	95	13-3/4	11	9-1/2	8	3/4-10	1	1-3/4	1-1/2	3/4	26	33
8	8	85	50	25	80	16	13-1/2	11-3/4	8	3/4-10	1-1/8	2	1-3/4	7/8	23	52
10	8	75	40	20	80	18-3/4	16	14-1/4	12	7/8-9	1-1/8	2	1-3/4	7/8	19	70
12	9	75	40	20	80	22-3/8	19	17	12	7/8-9	1-1/8	2-1/4	2	1	18	105

Notes:

- 1.) Movements are non-concurrent. Contact General Rubber for concurrent movement, and for sizes not shown up to 24" I.D.
- 2.) For full product specifications and installation instructions, see SPEC 3305-1 and ININ 3305-1.

- 3.) **WARNING:** Control units (integral limit bolts) must be used when piping is not properly anchored. Expansion joints may operate in pipelines carrying fluids at elevated temperatures and pressures, so precaution should be taken to ensure proper installation and regular inspection. Care is required to protect personnel in the event of leakage or splash. Adequate floor drains are always recommended.

