

Maxi-Joint®

Double (2) Wide Arch Expansion Joints

Style 1102, 1202

Features:

- Double the movement with 1/2 the spring rate
- Versatile hand-built construction. Made in the U.S.A
- Standard or custom face to face dimensions
- Wide flowing arch design
- Exceptional all directional movement capability
- Virtually eliminates sediment buildup
- Higher pressure rating than conventional expansion joints
- Excellent chemical and abrasion resistance
- Full vacuum rating (30" Hg) for style 1202
- 250°F continuous service standard, 400°F available
- Filled arch design available
- Hot dip galvanized retaining rings standard
- Absorbs noise, vibration and shock
- Compensates for minor misalignment and offset
- Low stiffness and deflection forces
- Integrally flanged design, no gaskets required
- Simple to install and high strength
- Provides easy access to piping and equipment
- Other standard drilling available, including ASA 300, DIN, PN, JIS, API, and Navy
- Wide variety of tube and cover elastomers available, including Pure Gum Rubber, EPDM, Neoprene, Butyl, Nitrile, Hypalon®, Viton®, Teflon®, Food Grade, and more



Style 1102, 1202

Double (2) Wide Arch Expansion Joints
Double the Movement with 1/2 the Spring Rate

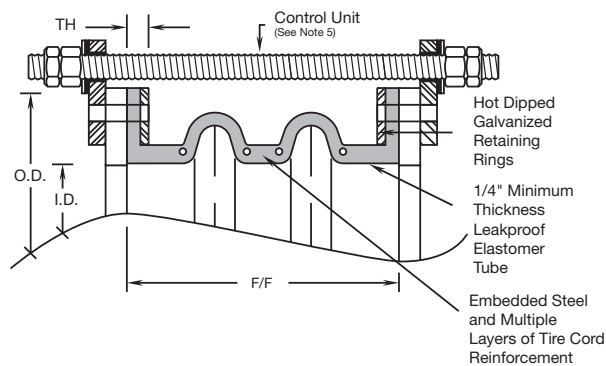

Optional Filled Arch Construction Also Typical for Other Styles

SIZE I.D. (inch)	LENGTH F/F (inch)	MAX Pressure (PSIG)	VACUUM Rating (inch Hg)	FLANGES - 125/150 LB. (NOTE 8)					MOVEMENTS					SPRING RATE			GROSS Weight (lbs)
				O.D. (inch)	B.C. (inch)	Hole (no.)	Hole (inch)	TH. (inch)	Comp. (inch)	Ext. (inch)	Lateral (inch)	Angular (degree)	Torsional (degree)	Comp. (lbs/in)	Ext. (lbs/in)	Lateral (lbs/in)	
2	10	220	15	6	4-3/4	4	3/4	7/8	3 1/2	1 3/4	2	78	8	135	170	225	12
2-1/2	10	220	15	7	5-1/2	4	3/4	7/8	3 1/2	1 3/4	2	66	7.6	170	210	240	14
3	10	220	15	7-1/2	6	4	3/4	7/8	3 1/2	1 3/4	2	56	7.4	200	255	270	17
4	10	220	15	9	7-1/2	8	3/4	7/8	3 1/2	1 3/4	2	44	7.2	275	355	295	21
5	10	220	15	10	8-1/2	8	7/8	7/8	3 1/2	1 3/4	2	36	6.8	335	440	355	24
6	10	220	15	11	9-1/2	8	7/8	7/8	3 1/2	1 3/4	2	30	6.4	410	525	395	29
8	10	220	15	13-1/2	11-3/4	8	7/8	7/8	3 1/2	1 3/4	2	24	6.2	495	580	480	42
10	12	220	15	16	14-1/4	12	1	7/8	4	2	2 1/2	34	6	480	585	410	53
12	12	220	15	19	17	12	1	7/8	4	2	2 1/2	28	5.8	505	625	485	69
14	12	220	15	21	18-3/4	12	1-1/8	1	4 1/2	2 1/4	2 1/2	24	5.6	540	650	570	93
16	12	160	15	23-1/2	21-1/4	16	1-1/8	1	4 1/2	2 1/4	2 1/2	22	5.4	575	695	660	110
18	12	160	15	25	22-3/4	16	1-1/4	1	4 1/2	2 1/4	2 1/2	20	5.2	610	785	725	119
20	12	130	15	27-1/2	25	20	1-1/4	1	4 1/2	2 1/4	2 1/2	18	5	640	875	810	143
24	15	130	15	32	29-1/2	20	1-3/8	1 1/8	5	2 1/2	2 3/4	16	4.8	865	1,050	870	166
30	15	100	10	38-3/4	36	28	1-3/8	1 1/8	5	2 1/2	2 3/4	14	4.6	1,090	1,330	1,095	225
36	15	90	10	46	42-3/4	32	1-5/8	1 1/8	5	2 1/2	2 3/4	12	4.4	1,330	1,625	1,340	304
42	16	90	10	53	49-1/2	36	1-5/8	1 1/8	5	2 1/2	3	9.6	4.2	1,515	1,825	1,510	378
48	16	90	10	59-1/2	56	44	1-5/8	1 1/8	5	2 1/2	3	8.4	4	1,695	2,075	1,705	449
54	16	85	10	66-1/4	62-3/4	44	2	1 1/8	5	2 1/2	3	7.6	3.8	2,060	2,510	2,070	547
60	16	85	10	73	69-1/4	52	2	1 1/8	5	2 1/2	3	7.2	3.6	2,260	2,780	2,290	646
66	16	85	10	80	76	52	2	1 1/8	5	2 1/2	3	6.6	3.4	2,625	3,195	2,635	749
72	16	85	10	86-1/2	82-1/2	60	2	1 1/4	5	2 1/2	3	6	3.2	2,950	3,590	2,960	826
78	16	80	10	93	89	64	2-1/8	1 1/4	5	2 1/2	3	5.2	3	3,210	3,925	3,285	1,088
84	16	80	10	99-3/4	95-1/2	64	2-1/4	1 1/4	5	2 1/2	3	4.6	2.8	3,475	4,335	3,700	1,338
90	16	80	10	106-1/2	102	68	2-3/8	1 1/4	5	2 1/2	3	4.2	2.6	3,635	4,600	4,040	1,474
96	16	80	10	113-1/4	108-1/2	68	2-1/2	1 1/4	5	2 1/2	3	4	2.4	3,825	5,050	4,535	1,583
102	16	60	10	120	114-1/2	72	2-5/8	1 3/8	5	2 1/2	3	3.2	1.6	4,064	5,365	4,820	1,682
108	16	60	10	126-3/4	120-3/4	72	2-5/8	1 3/8	5	2 1/2	3	3	1.4	4,303	5,680	5,100	1,780

- Notes:
- Series 1200 are designed for 30" Hg (full vacuum) and have a maximum test at 26" Hg due to facility altitude and equipment limitations.
 - Maximum operating temperature of 250 deg F for EPDM, Butyl, Hypalon, and Viton; 225 deg F for Neoprene; 210 deg F for Nitrile; 180 deg F for Pure Gum Rubber; 300 deg F for EPDM and Butyl in air service at 25 PSI maximum; higher pressure and temperature ratings available.
 - All sizes can be supplied with a filled arch reducing their movements by 50% and increasing the spring rates fourfold.
 - For full product specifications and installation instructions, see SPEC 1102-1 and ININ 1102-1. Gross weights include retaining rings.
 - WARNING:** Control units (sold separately) must be used when piping is not properly anchored. Number of rods are dependent upon maximum field test pressures. Expansion joints may operate in pipelines carrying fluids at elevated temperatures and pressures, so precaution should be taken to ensure proper installation and regular inspection. Care is required to protect personnel in the event of leakage or splash. Adequate floor drains are always recommended.
 - Movements are non-concurrent. Contact General Rubber for concurrent movements, and for sizes not shown up to 144" I.D.
 - Series 1100 and 1200 replace styles 1025, 1050 and 1075.
 - Standard 125/150 lb. drilling includes, 1"-24" with ANSI B16.1 Class 125 lb./B16.5 Class 150 lb., 30"-60" with ANSI B16.1 Class 125 lb./B16.47 series A, Class 150 lb., 72"-108" with ANSI B16.1 Class 125 lb./AWWA C207 Class B.

