

# Maxi-Joint®

Duct Type Expansion Joints with Rigid Flanges

## Style 1094

### Features:

- Up to 1,000°F and ± 3 PSI continuous service
- 1/2" thick laminated fiberglass insulation layer
- Laminated fluoroplastic PTFE corrosion barrier
- Round and rectangular designs in all styles
- Exceptional all directional movement capability
- Absorbs system noise, vibration and shock
- Compensates for minor misalignment and offset
- Integrally flanged design
- Low stiffness and deflection forces
- Simple to install, lightweight and high strength
- Provides easy access to ducting and equipment
- Carbon steel, stainless steel, or hot dipped galvanized backup rings available for easy bolting to mating flanges
- Heat form and sealed to any size and arrangement

1094 – MOLDED FLANGE VERSATILE FACE TO FACE CONSTRUCTION				
Installed LENGTHS (inch)	MFD F/F + (inch)	MOVEMENT CAPABILITIES (inch)		
		Comp.	Ext.	Lateral
3-1/2 - 6	1/2	2	1/2	1
6-1/2 - 9	3/4	3	3/4	2
9-1/2 - 12	1	4	1	3
12-1/2 - 16	1	5	1	4

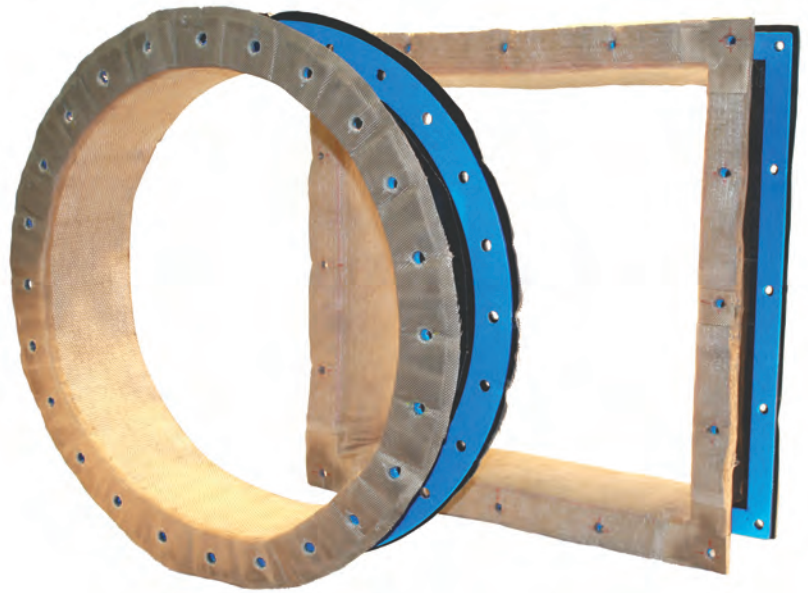

## Style 1094

Single (Fully Laminated) Layer Expansion Joints

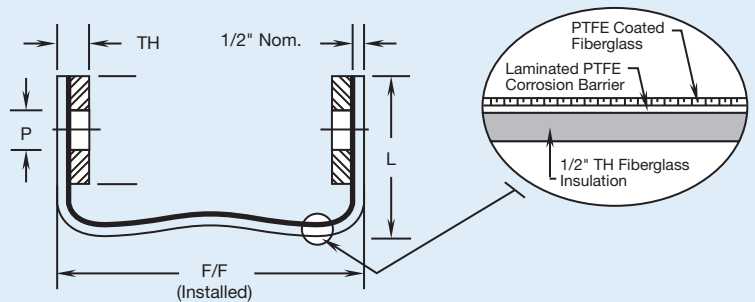
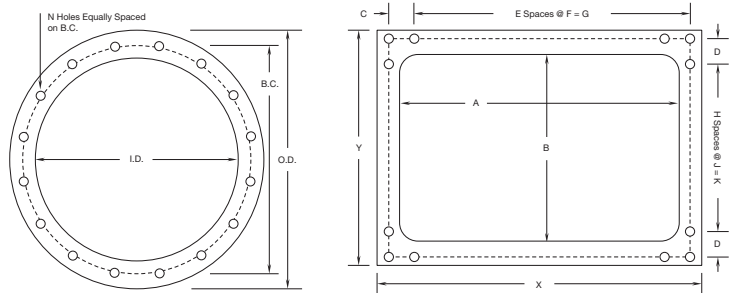

### Notes:

- 1.) Extension movement capabilities can be increased with additional pre-compression during installation.
- 2.) Anchors should be used to resist the pressure thrust force and isolate the thermal movements between expansion joints.
- 3.) For vacuum or large pre-compressed applications, a set-back may be required to keep the expansion joint from protruding into the gas stream or touching the flow liner/baffle.
- 4.) Retaining Rings/ Backing Bars of 1/4" thickness standard. – Suggested bolt spacing at 4" centers max.
- 5.) Flange gaskets suitable for the system temperature and fluid media should be used to ensure a full seal on all fluoroplastic styles. (Style 1094)
- 6.) For full product specifications and installation instructions, see SPEC 1094-1 and ININ 1094-1.

