

Maxi-Joint®

Molded Wide Arch Expansion Joint

Style 1015

Features:

- Wide flowing arch design
- Exceptional all directional movement capability
- Virtually eliminates sediment buildup
- Higher pressure rating than conventional expansion joints
- Excellent chemical and abrasion resistance
- Full vacuum rating (30" Hg) in all sizes
- 250°F continuous service standard, 400°F available
- Filled arch design available
- Economical fully molded construction
- Standard face to face dimensions with ANSI 125/150 lb. drilling
- Hot dipped galvanized retaining rings standard
- Absorbs noise, vibration and shock
- Compensates for minor misalignment and offset
- Low stiffness and deflection forces
- Integrally flanged design, no gaskets required
- Large inventory means quick shipments
- Simple to install, lightweight and high strength
- Provides easy access to piping and equipment
- Wide variety of tube and cover elastomers available, including Pure Gum Rubber, EPDM, Neoprene, Butyl, Nitrile, Hypalon®, Viton®, Teflon®, Food Grade, and more



Style 1015

Single (1) Wide Arch,
Spool Type, Expansion Joint

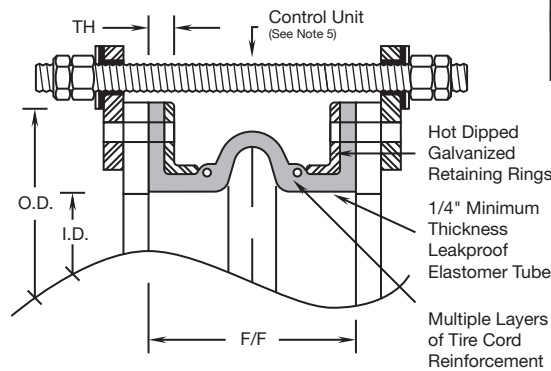

Optional Filled Arch
Construction
Also Typical for
Other Styles

Notes:

- 1.) All parts listed are designed for 30" Hg (full vacuum) and have a maximum test at 26" Hg due to facility altitude and equipment limitations.
- 2.) Maximum operating temperature of 250°F for EPDM, Butyl, Hypalon®, and Viton®; 225°F for Neoprene; 210°F for Nitrile; 180°F for Pure Gum Rubber; 300°F for EPDM and Butyl in air service at 25 PSI maximum; higher pressure and temperature ratings available.
- 3.) All sizes can be supplied with a filled arch reducing their movements by 50% and increasing the spring rates fourfold.
- 4.) For full product specifications and installation instructions, see SPEC 1015-1, SPEC 1015T-1 and ININ 1015-1, ININ 1015T-1. Gross weights include retaining rings.
- 5.) **WARNING:** Control units (sold separately) must be used when piping is not properly anchored. Number of rods are dependent upon maximum field test pressures. Expansion joints may operate in pipelines carrying fluids at elevated temperatures and pressures, so precaution should be taken to ensure proper installation and regular inspection. Care is required to protect personnel in the event of leakage or splash. Adequate floor drains are always recommended.
- 6.) Movements are non-concurrent. Contact General Rubber for concurrent movements, and for sizes not shown up to 144" I.D.
- 7.) Retaining rings are typically "L" shaped for sizes 1" through 16", and can be flat depending on internal reinforcements and for sizes 18" and larger.
- 8.) Standard 125/150 lb. drilling includes, 1"-24" with ANSI B16.1 Class 125 lb./B16.5 Class 150 lb., 30"-60" with ANSI B16.1 Class 125 lb./ B16.47 series A, Class 150 lb., 72"-108" with ANSI B16.1 Class 125 lb./ AWWA C207 Class B.

4

Toll Free: 800-233-6294
Web: www.general-rubber.com



general rubber corporation

Fax: 201-935-1915
sales@general-rubber.com

Maxi-Joint®

Teflon® Lined Molded Wide Arch Expansion Joint

Style 1015T

Features:

- Superior chemical resistance even at higher temperatures and pressures
- Wide flowing arch design
- Exceptional all directional movement
- Integrally flanged design, no gaskets required
- Liner made of 100% virgin DuPont Teflon®
- Ideal for food, pharmaceutical, chemical and ultra pure water applications
- Multiple arches available



Style 1015T
Teflon Lined,
Expansion Joint

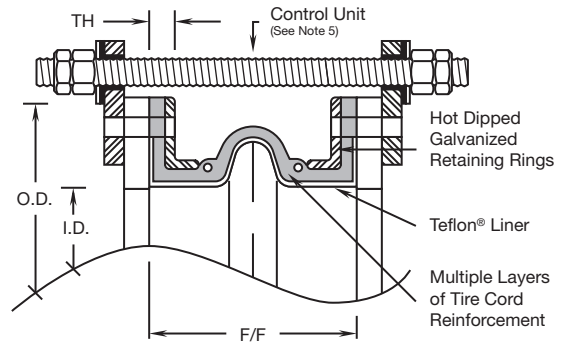

SIZE I.D. (inch)	LENGTH F/F (inch)	MAX Pressure (PSIG)	VACUUM Rating (inch Hg)	FLANGES - 125/150 LB. (NOTE 8)					MOVEMENTS					SPRING RATE			GROSS Weight (lbs)
				O.D. (inch)	B.C. (inch)	Holes (no.)	Hole (inch)	TH. (inch)	Comp. (inch)	Ext. (inch)	Lateral (inch)	Angular (degree)	Torsional (degree)	Comp. (lbs/in)	Ext. (lbs/in)	Lateral (lbs/in)	
1	6	200	30	4-1/4	3-1/8	4	5/8	13/16	1-1/4	1/2	1/2	50	4.4	199	272	368	4
1-1/2	6	200	30	5	3-7/8	4	5/8	13/16	1-1/4	1/2	1/2	44	4.1	208	294	365	5
2	6	200	30	6	4-3/4	4	3/4	13/16	1-3/4	3/4	3/4	39	4	214	272	363	5.5
2-1/2	6	200	30	7	5-1/2	4	3/4	13/16	1-3/4	3/4	3/4	33	3.8	272	340	385	7.5
3	6	200	30	7-1/2	6	4	3/4	13/16	1-3/4	3/4	3/4	28	3.7	320	408	431	8.5
4	6	200	30	9	7-1/2	8	3/4	13/16	1-3/4	3/4	3/4	22	3.6	437	567	476	10
5	6	200	30	10	8-1/2	8	7/8	13/16	1-3/4	3/4	3/4	18	3.4	534	703	567	12.5
6	6	200	30	11	9-1/2	8	7/8	13/16	1-3/4	3/4	1	15	3.2	650	839	629	16.5
8	6 or 8	190	30	13-1/2	11-3/4	8	7/8	7/8	1-3/4	3/4	1	12	3.1	719	929	765	22
10	8	190	30	16	14-1/4	12	1	7/8	1-3/4	3/4	1	17	3	903	1,179	816	34
12	8	190	30	19	17	12	1	7/8	1-3/4	3/4	1	14	2.9	943	1,247	969	45
14	8	130	30	21	18-3/4	12	1-1/8	15/16	2	7/8	1-1/8	12	2.8	1,012	1,302	1,133	55
16	8	110	30	23-1/2	21-1/4	16	1-1/8	15/16	2	7/8	1-1/8	11	2.7	1,080	1,399	1,315	64
18	8	110	30	25	22-3/4	16	1-1/4	1	2	7/8	1-1/8	10	2.6	1,216	1,573	1,451	71
20	8	110	30	27-1/2	25	20	1-1/4	1	2	7/8	1-1/8	9	2.5	1,225	1,749	1,617	82
24	10	100	30	32	29-1/2	20	1-3/8	1-1/8	2-1/4	1	1-1/4	8	2.4	1,617	2,108	1,738	102
30	10	100	30	38-3/4	36	28	1-3/8	1-1/8	2-1/4	1	1-1/4	7	2.3	2,040	2,660	2,192	140
36	10	90	30	46	42-3/4	32	1-5/8	1-1/8	2-1/4	1	1-1/4	6	2.2	2,494	3,250	2,678	190
40	12	80	30	50-3/4	47-1/4	36	1-5/8	1-1/8	2-1/4	1	1-3/8	5.1	2.1	2,698	3,481	2,871	224
42	12	80	30	53	49-1/2	36	1-5/8	1-1/8	2-1/4	1	1-3/8	4.8	2.1	2,833	3,655	3,014	235
48	12	80	30	59-1/2	56	44	1-5/8	1-1/8	2-1/4	1	1-3/8	4.2	2	3,173	4,153	3,411	290
54	12	80	30	66-1/4	62-3/4	44	2	1-1/8	2-1/4	1	1-3/8	3.8	1.9	3,853	5,022	4,140	350
60	12	80	30	73	69-1/4	52	2	1-1/8	2-1/4	1	1-3/8	3.6	1.8	4,224	5,565	4,587	420
66	12	80	30	80	76	52	2	1-1/8	2-1/4	1	1-3/8	3.3	1.7	4,911	6,398	5,276	460
72	12	80	30	86-1/2	82-1/2	60	2	1-1/8	2-1/4	1	1-3/8	3	1.6	5,516	7,186	5,924	530
78	12	80	30	93	89	64	2-1/8	1-1/8	2-1/4	1	1-3/8	2.6	1.5	6,000	7,850	6,578	580
84	12	80	30	99-3/4	95-1/2	64	2-1/4	1-1/8	2-1/4	1	1-3/8	2.3	1.4	6,498	8,670	7,404	630
90	12	70	30	106-1/2	102	68	2-3/8	1-1/8	2-1/4	1	1-3/8	2.1	1.3	6,800	9,200	8,089	855
96	12	70	30	113-1/4	108-1/2	68	2-1/2	1-1/8	2-1/4	1	1-3/8	2	1.2	7,156	10,100	9,067	1,000
102	12	60	30	120	114-1/2	72	2-5/8	1-3/8	2-1/4	1	1-3/8	1.8	1.0	7,603	10,711	9,634	1,065
108	12	60	30	126-3/4	120-3/4	72	2-5/8	1-3/8	2-1/4	1	1-3/8	1.7	0.9	8,050	11,323	10,200	1,125

