

Flex-Valve®

Manual, Electric and Pneumatic Interchangeable Pinch Valves

Series 2300

Features:

- Enclosed body design
- Interchangeable with Plug Valves in all sizes
- Modular design for easy conversion, even in-line, between manual, electric and pneumatic actuation
- Dual pinching mechanism closes from top and bottom to center
- 100% full port eliminates clogging and turbulence while minimizing pressure drops
- Nonrising actuators for safety and rigid connections
- Operating torques will remain constant over time, even when left open or closed for years
- Available completely sealed with body mounted gauge or pressure switches for fugitive emissions, submerged or buried service
- Prevents scaling buildup and clogging with its unobstructed design and flexing action
- Rubber sleeve is the only part exposed to the process fluid
- Drop-tight bi-directional closure, even on solids
- Flanges tapped to ANSI 125/150 lb.
- Full flat-faced integral elastomer flanges
- Can be installed in any position
- Positive opening device standard
- No packing, gaskets or seals to maintain
- This versatile retrofit valve is ideal for many plant upgrades and modernization projects



Style 2300
Hand Wheel Actuation

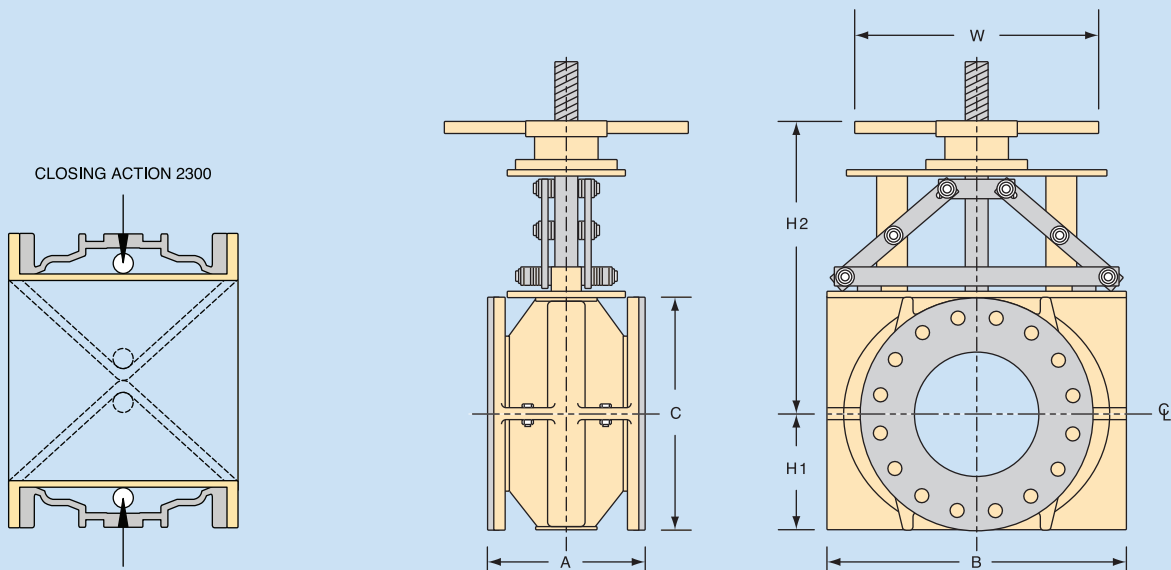

The Non-Plug Valve® Interchangeable with Plug Valves in All Sizes

VALVE SIZE	DIMENSIONS									
	4	6	8	10	12	14	16	18	20	24
2300										
A	9	10-1/2	11-1/2	13	14	17	17-3/4	21-1/2	23-1/2	42
B	16	20	23	25	28	32	37	41	45	50
C	9	11	13-1/2	16	19	21	23-1/2	25	27-1/2	32
H1	4-1/2	5-1/2	6-3/4	8	9-1/2	10-1/2	11-3/4	12-1/2	13-3/4	16
W	12	18	22	BG	BG	BG	BG	BG	BG	BG
H2	16	19	20	22	24	28	32	33	36	46
Approx Weight (Lbs)	86	130	180	250	500	670	750	910	1200	1400
2300EA										
W	28	28	34	34	34	34	36-1/2	36-1/2	36-1/2	41
H2	39-1/2	40	42	50	52	54	55	56	57	69
Approx Weight (Lbs)	360	460	690	840	1050	1450	1800	2120	2300	4060
2300PA										
W	*	*	*	*	*	*	*	*	*	*
H2	40	48	51	54	60	63	65	67	70	78
Max. Pressure (PSIG)	150	150	150	100	100	75	50	50	50	50
Approx Weight (Lbs)	185	245	700	1050	1410	1500	1750	2200	2600	4300

Notes: 1) A bevel gear is recommended for sizes 10" and over for manual service. 2) BG - Bevel Gear installed on Pinch Valve (2300BG). 3) Width of cylinder is dependent upon process line pressure. 4) For full product specifications and installation instructions, see SPEC2300-1, SPEC2300EA-1, SPEC2300PA-1 and ININ2300-1, ININ2300EA-1, ININ2300PA-1, respectively. 5) All dimensions expressed in inches. Contact General Rubber for sizes not shown and higher pressure ratings. 6) WARNING: Pinch valves may operate in pipelines carrying fluids at elevated temperatures and pressures, so precaution should be taken to ensure proper installation and regular inspection. Care is required to protect personnel in the event of leakage or spray. Adequate floor drains for indoor applications are always recommended.

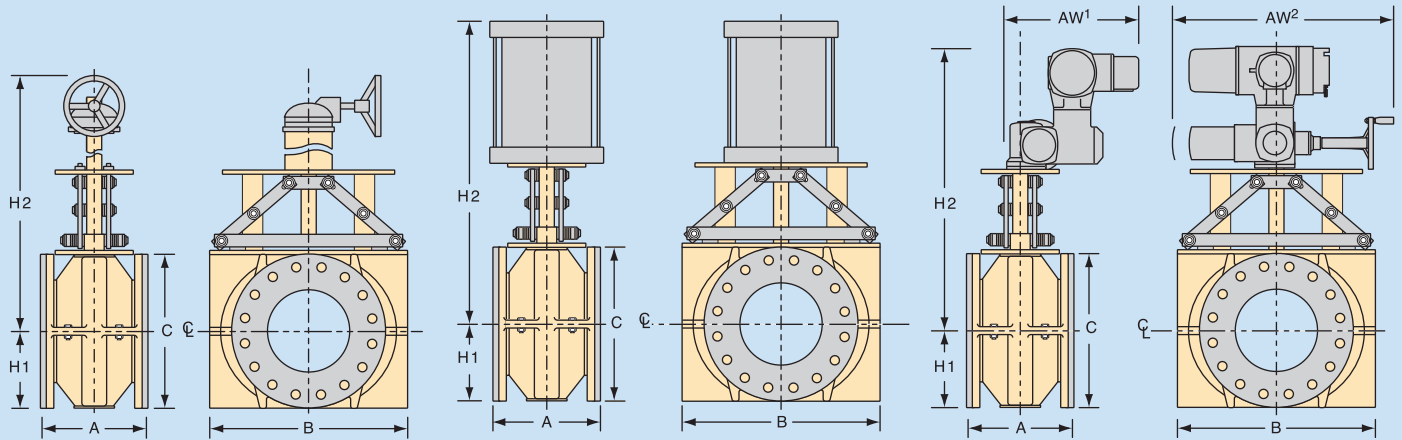

DIMENSIONS BASED UPON ATO/ATC CYLINDER AND ARE FOR REFERENCE ONLY.



Style 2300BG
Bevel Gear Actuation



Style 2300PA
Pneumatic Actuation



Style 2300EA
Electronic Actuation

