

# Flex-Valve®

## Manual, Electric and Pneumatic Control Pinch Valves

### Series 2200

#### Features:

- Enclosed body design
- Conforms to ISA control pinch valve standard S75.08
- Modular design for easy conversion, even in-line, between manual, electric, and pneumatic actuation
- Nonrising actuation for safety and ridged connections
- Operating torques will remain constant over time, even when left open or closed for years
- Available completely sealed with body mounted gauge or pressure switch for fugitive emissions, submerged or buried service
- Prevents scaling buildup and clogging with its unobstructed design and flexing action
- Rubber sleeve is the only part exposed to the process fluid
- Drop-tight bi-directional closure, even on solids
- Flanges tapped for ANSI 125/150 lb.
- Full flat-faced integral elastomer flanges
- Can be installed in any position
- Positive opening device standard
- No packing, gaskets or seals to maintain
- The control valve of choice for most wastewater treatment plants and light industrial plants

### Style 2200EA Electronic Actuation

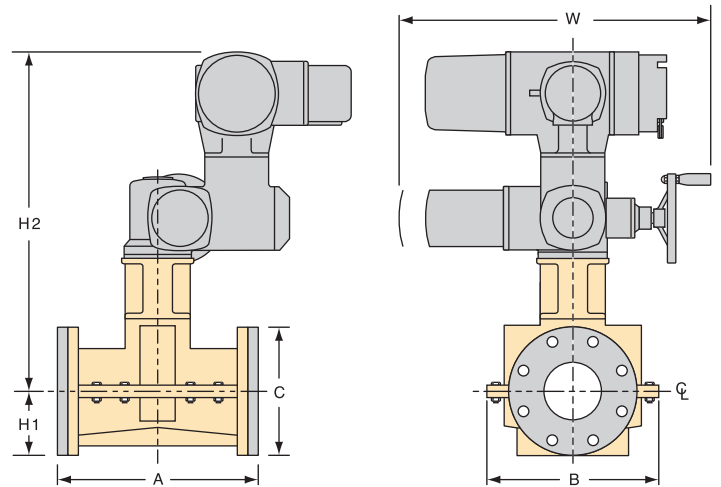
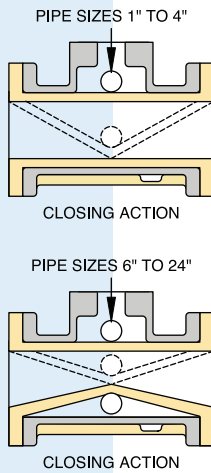

### Style 2200 Manual Actuation

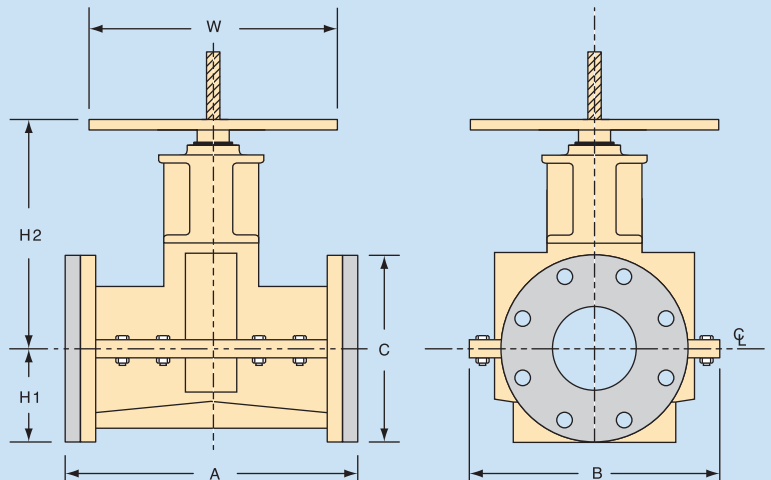

VALVE SIZE	DIMENSIONS														
	1	1-1/2	2	2-1/2	3	4	6	8	10	12	14	16	18	20	24
Max. Pressure (PSIG)	150	150	150	150	150	150	150	125	100	100	75	50	50	50	50
2200															
A	7-1/4	8-3/4	10	10-7/8	11-3/4	13-7/8	18	21-3/8	26-1/2	29	28	32	36	40	48
B	6-1/2	6-1/2	8-1/4	8-1/4	9-1/2	12-1/2	14	18	22-7/8	26-1/4	32	37	44	47	52
C	4-1/4	5	6	7	7-1/2	9	11	13-1/2	16	19	21	23-1/2	25	27-1/2	32
H1	2-1/8	2-1/2	3	3-1/2	3-3/4	4-1/2	5-1/2	6-3/4	8	9-1/2	10-1/2	11-3/4	12-1/2	13-3/4	16
W	8	8	8	8	12	12	18	22	BG	BG	BG	BG	BG	BG	BG
H2	8	8	9	9	11	11-1/2	16	17	19	21	25	29	34	38	41
Approx Weight (Lbs)	17	38	50	65	76	125	235	305	615	850	950	1100	1300	1420	1900
2200EA															
W	19-1/2	19-1/2	20-1/2	20-1/4	21-1/4	28	28	34	34	34	34	36-1/2	36-1/2	36-1/2	41
H2	29	29	29	29	30	35	36	37	40	40	42	44	47	50	55
Approx Weight (Lbs)	85	135	170	200	230	350	440	670	800	995	1500	1900	2650	3200	3900
2200PA															
W	*	*	*	*	*	*	*	*	*	*	*	*	*	*	*
H2	17	19	21	23	26	32	40	43	46	53	55	57	59	62	70
Approx Weight (Lbs)	42	47	80	83	100	175	220	650	990	1340	1400	1600	2000	2500	4300
2200DA															
W	8-1/2	8-1/2	15	15	18	18	26	26	N/A	N/A	N/A	N/A	N/A	N/A	N/A
H2	10-1/2	10-3/4	11-1/2	12	16	16-1/2	20	21	N/A	N/A	N/A	N/A	N/A	N/A	N/A
Approx Weight (Lbs)	30	45	75	90	110	150	260	320	N/A	N/A	N/A	N/A	N/A	N/A	N/A

Notes: 1) BG - Bevel Gear installed on Pinch Valve. 2) Width of cylinder is dependent upon process line pressure. Some valves shown with optional accessories. 3) For full product specifications and installation instructions, see SPEC2200-1, SPEC2200EA-1, SPEC2200PA-1 and ININ2200-1, ININ2200EA-1, ININ2200PA-1, respectively. 4) WARNING: Pinch valves may operate in pipelines carrying fluids at elevated temperatures and pressures, so precaution should be taken to ensure proper installation and regular inspection. Care is required to protect personnel in the event of leakage or spray. Adequate floor drains for indoor applications are always recommended.

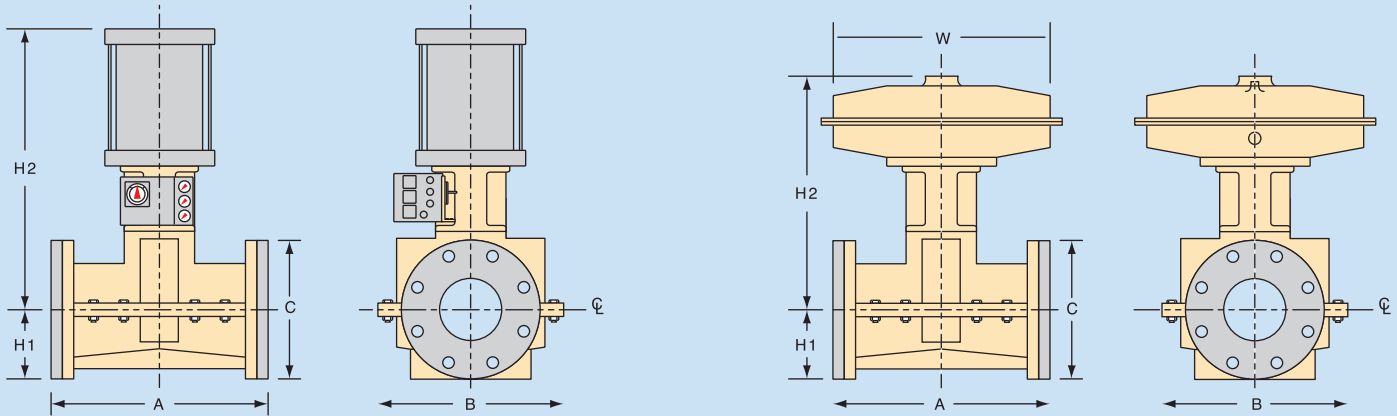

DIMENSIONS BASED UPON ATO/ATC CYLINDER AND ARE FOR REFERENCE ONLY.

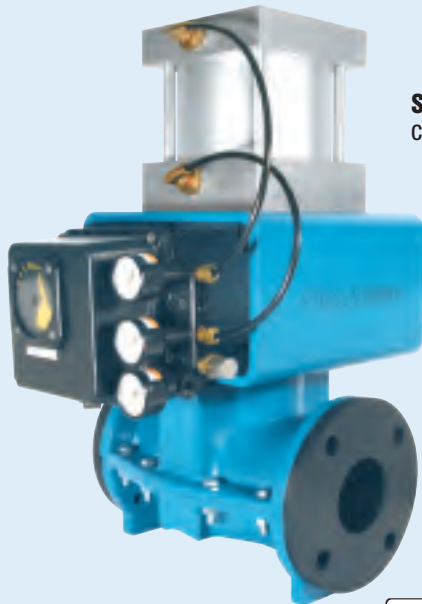

Style **2200PA**  
Cylinder Actuation



Style **2200DA**  
Diaphragm Actuation

